

TPIC44L01, TPIC44L02, TPIC44L03 4-CHANNEL SERIAL AND PARALLEL LOW-SIDE PRE-FET DRIVER

SLIS062B – NOVEMBER 1996 – REVISED AUGUST 2001

- 4-Channel Serial-In Parallel-In Low-Side Pre-FET Driver
- Devices Are Cascadable
- Internal 55-V Inductive Load Clamp and V_{GS} Protection Clamp for External Power FETs
- Independent Shorted-Load/Short-to-Battery Fault Detection on All Drain Terminals
- Independent OFF-State Open-Load Fault Sense
- Over-Battery-Voltage Lockout Protection and Fault Reporting
- Under-Battery Voltage Lockout Protection for the TPIC44L01 and TPIC44L02
- Asynchronous Open-Drain Fault Flag
- Device Output Can Be Wire-ORed With Multiple Devices
- Fault Status Returned Through Serial Output Terminal
- Internal Global Power-On Reset of Device and External RESET Terminal
- High-Impedance CMOS-Compatible Inputs With Hysteresis
- TPIC44L01 and TPIC44L03 Disables the Gate Output When a Shorted-Load Fault Occurs
- TPIC44L02 Transitions the Gate Output to a Low-Duty Cycle PWM Mode When a Shorted-Load Fault Occurs

description

The TPIC44L01, TPIC44L02, and TPIC44L03 are low-side predrivers that provide serial and parallel input interfaces to control four external FET power switches such as offered in the TI TPIC family of power arrays. These devices are designed primarily for low-frequency switching, inductive load applications such as solenoids and relays. Fault status for each channel is available in a serial-data format. Each driver channel has independent off-state open-load detection and on-state shorted-load/short-to-battery detection. Battery overvoltage and undervoltage detection and shutdown is provided on the TPIC44L01/L02. On the TPIC44L03 driver, only over-battery voltage shutdown is provided. Each channel also provides inductive-voltage-transient protection for the external FET.

These devices provide control of output channels through a serial input interface or a parallel input interface. A command to enable the output from either interface enables the respective channels gate output to the external FET. The serial interface is recommended when the number of signals between the control device and the predriver must be minimized and the speed of operation is not critical. In applications where the predriver must respond very quickly or asynchronously, the parallel input interface is recommended.

For serial operation, the control device must transition \overline{CS} from high to low to activate the serial input interface. When this occurs, SDO is enabled, fault data is latched into the serial interface, and the fault flag is refreshed.

DB PACKAGE
(TOP VIEW)

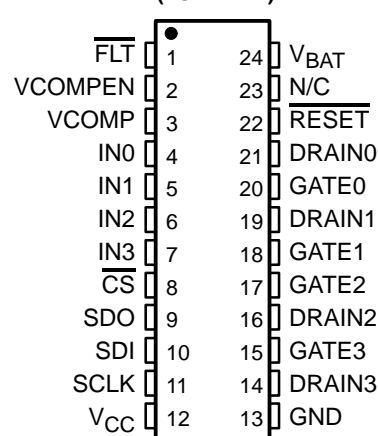

Please be aware that an important notice concerning availability, standard warranty, and use in critical applications of Texas Instruments semiconductor products and disclaimers thereto appears at the end of this data sheet.

PRODUCTION DATA information is current as of publication date. Products conform to specifications per the terms of Texas Instruments standard warranty. Production processing does not necessarily include testing of all parameters.

 **TEXAS
INSTRUMENTS**

POST OFFICE BOX 655303 • DALLAS, TEXAS 75265

Copyright © 2001, Texas Instruments Incorporated

TPIC44L01, TPIC44L02, TPIC44L03

4-CHANNEL SERIAL AND PARALLEL LOW-SIDE PRE-FET DRIVER

SLIS062B – NOVEMBER 1996 – REVISED AUGUST 2001

description (continued)

Data is clocked into the serial registers on low-to-high transitions of SCLK through SDI. Each string of data must consist of at least four bits of data. In applications where multiple devices are cascaded together, the string of data must consist of four bits for each device. A high data bit turns the respective output channel on and a low data bit turns it off. Fault data for the device is clocked out of SDO as serial input data is clocked into the device. Fault data consists of fault flags for shorted-load and open-load flags (bits 0–3) for each of the four output channels. A high bit in the fault data indicates a fault and a low bit indicates that no fault is present for that channel. Fault register bits are set or cleared asynchronously to reflect the current state of the hardware. A fault must be present when \overline{CS} is transitioned from high to low to be captured and reported in the serial fault data. New faults cannot be captured in the serial register when \overline{CS} is low. \overline{CS} must be transitioned high after all of the serial data has been clocked into the device. A low-to-high transition of \overline{CS} transfers the last four bits of serial data to the output buffer puts SDO in a high-impedance state and clears and reenables the fault register. The TPIC44L01/L02/L03 was designed to allow the serial input interfaces of multiple devices to be cascaded together to simplify the serial interface to the controller. Serial input data flows through the device and is transferred out SDO following the fault data in cascaded configurations.

For parallel operation, data is transferred directly from the parallel input interface IN0-IN3 to the respective GATE(0–3) output asynchronously. SCLK or \overline{CS} is not required for parallel control. A 1 on the parallel input turns the respective channel on, where a 0 turns it off. Note that either the serial input interface or the parallel input interface can enable a channel. Under parallel operation, fault data must still be collected through the serial data interface.

The predrivers monitor the drain voltage for each channel to detect shorted-load or open-load fault conditions in the on and off states respectively. These devices offer the option of using an internally generated fault-reference voltage or an externally supplied fault-reference voltage through VCOMP for fault detection. The internal fault reference is selected by connecting VCOMPEN to GND and the external reference is selected by connecting VCOMPEN to V_{CC} . The drain voltage is compared to the fault reference when the channel is turned on to detect shorted-load conditions and when the channel is off to detect open-load conditions. When a shorted fault occurs using the TPIC44L01 or the TPIC44L03, the channel is turned off and a fault flag is sent to the control device as well as to the serial fault register bits. If a fault occurs while using the TPIC44L02, the channel transitions into a low-duty cycle, pulse-width-modulated (PWM) signal as long as the fault is present. Shorted-load fault conditions must be present for at least the shorted-load deglitch time, $t_{(STBDG)}$, to be flagged as a fault. A fault flag is sent to the control device as well as the serial fault register bits. More detail on fault detection operation is presented in the device operation section of this data sheet.

These devices provide protection from over-battery voltage and under-battery voltage conditions irrespective of the state of the output channels. When the battery voltage is greater than the overvoltage threshold or less than the undervoltage threshold, all channels are disabled and a fault flag is generated. Battery-voltage faults are not reported in the serial fault data. The outputs return to normal operation once the battery-voltage fault has been corrected. When an over-battery/under-battery voltage condition occurs, the device reports the battery fault, but disables fault reporting for open- and shorted-load conditions. Fault reporting for open- and shorted-load conditions are reenabled after the battery fault condition has been corrected.

These devices provide inductive transient protection on all channels. The drain voltage is clamped to protect the FET. The clamp voltage is defined by the sum of V_{CC} and turnon voltage of the external FET. The predriver also provides a gate-to-source voltage (V_{GS}) clamp to protect the gate-source terminals of the power FET from exceeding their rated voltages. An external active low \overline{RESET} is provided to clear all registers and flags in the device. GATE(0–3) outputs are disabled after \overline{RESET} has been pulled low.

These devices provide pulldown resistors on all inputs except \overline{CS} and \overline{RESET} . A pullup resistor is used on \overline{CS} and \overline{RESET} .



TPIC44L01, TPIC44L02, TPIC44L03 4-CHANNEL SERIAL AND PARALLEL LOW-SIDE PRE-FET DRIVER

SLIS062B – NOVEMBER 1996 – REVISED AUGUST 2001

schematic diagram

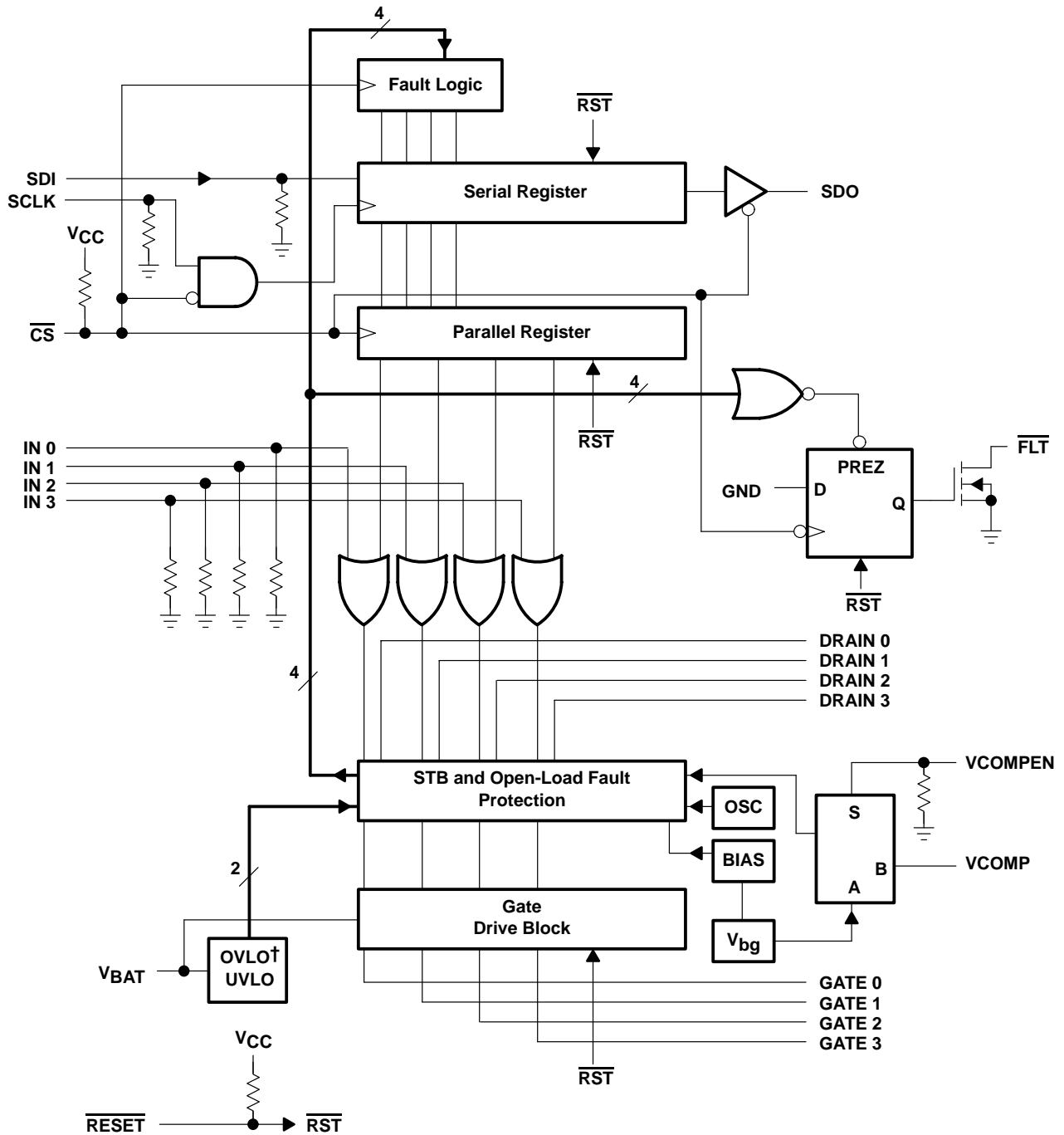

† OVLO not on TPIC44L03

TPIC44L01, TPIC44L02, TPIC44L03

4-CHANNEL SERIAL AND PARALLEL LOW-SIDE PRE-FET DRIVER

SLIS062B – NOVEMBER 1996 – REVISED AUGUST 2001

Terminal Functions

TERMINAL NAME	NO.	I/O	DESCRIPTION
\overline{CS}	8	I	Chip select. A high-to-low transition on \overline{CS} enables SDO, latches fault data into the serial interface, and refreshes \overline{FLT} . When \overline{CS} is high, the fault registers can change fault status. On the falling edge of \overline{CS} , fault data is latched into the serial output register and transferred using SDO and SCLK. On a low-to-high transition of \overline{CS} , serial data is latched in to the output control register.
DRAIN0 DRAIN1 DRAIN2 DRAIN3	21 19 16 14	I	FET drain inputs. DRAIN0 through DRAIN3 are used for both open-load and short-circuit fault detection at the drain of the external FETs. They are also used for inductive transient protection.
\overline{FLT}	1	I	Fault flag. \overline{FLT} is a logic level open-drain output that provides a real-time fault flag for shorted-load/open-load/over-battery voltage/under-battery voltage faults. The device can be ORed with \overline{FLT} terminals on other devices for interrupt handling. \overline{FLT} requires an external pullup resistor.
GATE0 GATE1 GATE2 GATE3	20 18 17 15	O	Gate drive output. GATE0 through GATE3 outputs are derived from the V_{BAT} supply voltage. Internal clamps prevent voltages on these nodes from exceeding the V_{GS} rating on most FETs.
GND	13	I	Ground and substrate
IN0 IN1 IN2 IN3	4 5 6 7	I	Parallel gate driver. IN0 through IN3 are real-time controls for the gate predrive circuitry. They are CMOS compatible with hysteresis.
\overline{RESET}	22	I	Reset. A high-to-low transition of \overline{RESET} clears all registers and flags. Gate outputs turn off and the \overline{FLT} flag is cleared.
SCLK	11	I	Serial clock. SCLK clocks the shift register. Serial data is clocked into SDI and serial fault data is clocked out of SDO on the falling edge of the serial clock.
SDI	10	I	Serial data input. Output control data is clocked into the serial register through SDI. A 1 on SDI commands a particular gate output on and a 0 turns it off.
SDO	9	O	Serial data output. SDO is a 3-state output that transfers fault data to the controlling device. It also passes serial input data to the next stage for cascaded operation. SDO is taken to a high-impedance state when \overline{CS} is in a high state.
V_{BAT}	24	I	Battery supply voltage
V_{CC}	12	I	Logic supply voltage
VCOMPEN	2	I	Fault reference voltage select. VCOMPEN selects the internally generated fault reference voltage (0) or an external fault reference (1) to be used in the shorted- and open-load fault detection circuitry.
VCOMP	3	I	Fault reference voltage. VCOMP provides an external fault reference voltage for the shorted-load and open-load fault detection circuitry.



TPIC44L01, TPIC44L02, TPIC44L03 4-CHANNEL SERIAL AND PARALLEL LOW-SIDE PRE-FET DRIVER

SLIS062B – NOVEMBER 1996 – REVISED AUGUST 2001

absolute maximum ratings over operating free-air temperature range (unless otherwise noted)†

Supply voltage range, V_{CC} (see Note 1)	–0.3 V to 7 V
Battery supply voltage range, V_{BAT}	–0.3 V to 60 V
Input voltage range, V_I (at any input)	–0.3 V to 7 V
Output voltage range, V_O (SDO and \overline{FLT})	–0.3 V to 7 V
Drain-to-source voltage, V_{DS}	–0.3 V to 60 V
Output voltage, V_O	–0.3 V to 15 V
Operating case temperature range, T_C	–40°C to 125°C
Thermal resistance, junction to ambient, $R_{\theta JA}$	135°C/W
Maximum junction temperature, T_J	150°C
Storage temperature range, T_{stg}	–40°C to 150°C

† Stresses beyond those listed under “absolute maximum ratings” may cause permanent damage to the device. These are stress ratings only, and functional operation of the device at these or any other conditions beyond those indicated under “recommended operating conditions” is not implied. Exposure to absolute-maximum-rated conditions for extended periods may affect device reliability.

NOTE 1: All voltage values are with respect to GND.

recommended operating conditions

	MIN	NOM	MAX	UNIT
Logic supply voltage, V_{CC}	4.5	5	5.5	V
Battery supply voltage, V_{BAT}	8		24	V
High-level input voltage, V_{IH}	$0.85 V_{CC}$		V_{CC}	V
Low-level input voltage, V_{IL}	0		$0.15 V_{CC}$	V
Setup time, SDI high before SCLK rising edge, t_{su} (see Figure 5)	10			ns
Hold time, SDI high after SCLK rising edge, t_h (see Figure 5)	10			ns
Case temperature, T_C	–40		125	°C



TPIC44L01, TPIC44L02, TPIC44L03

4-CHANNEL SERIAL AND PARALLEL LOW-SIDE PRE-FET DRIVER

SLIS062B – NOVEMBER 1996 – REVISED AUGUST 2001

electrical characteristics over recommended operating free-air temperature range (unless otherwise noted)

PARAMETER		TEST CONDITIONS	MIN	TYP	MAX	UNIT
I _{BAT}	Supply current, V _{BAT}	All outputs off, V _{BAT} = 12 V	300	500	700	μA
I _{CC}	Supply current, V _{CC}	All outputs off, V _{BAT} = 5.5 V	1	2.6	4.2	mA
V _(turnon)	Turnon voltage, logic operational, V _{CC}	V _{BAT} = 5.5 V, Check output functionality	2.6	3.5	4.4	V
V _(ovsd)	Over-battery-voltage shutdown	Gate disabled, See Figure 16	32	34	36	V
V _{hys(ov)}	Over-battery-voltage reset hysteresis		0.5	1	1.5	V
V _(uvsd)	Under-battery-voltage shutdown, (TPIC44L01/L02 only)	Gate disabled, See Figure 17	4.1	4.8	5.4	V
V _{hys(uv)}	Under-battery-voltage reset hysteresis, (TPIC44L01/L02 only)		100	200	300	mV
V _G	Gate drive voltage	8 V < V _{BAT} < 24 V, I _O = 100 μA	7		13.5	V
		5.5 V < V _{BAT} < 8 V, I _O = 100 μA	5		7	V
I _{O(H)}	Maximum current output for drive terminals, pullup	V _O = GND	0.5	1.2	2.5	mA
I _{O(L)}	Maximum current output for drive terminals, pulldown	V _O = 7 V	0.5	1.2	2.5	mA
V _(stb)	Short-to-battery/shorted-load/open-load detection voltage	V _{COMPEN} = L	1.1	1.25	1.4	V
V _{hys(stb)}	Short-to-battery hysteresis		40	100	150	mV
V _{D(open)}	Open-load off-state detection voltage threshold	V _{COMPEN} = L	1.1	1.25	1.4	V
V _{hys(open)}	Open-load hysteresis		40	100	150	mV
I _{I(open)}	Open-load off-state detection current		30	60	80	μA
I _{I(PU)}	Input pullup current (\overline{CS})	V _{CC} = 5 V, V _{IN} = 0 V		10		μA
I _{I(PD)}	Input pulldown current	V _{CC} = 5 V, V _{IN} = 5 V		10		μA
V _{hys}	Input voltage hysteresis	V _{CC} = 5 V	0.6	0.85	1.1	V
V _{O(SH)}	High-level serial output voltage	I _O = 1 mA	0.8 V _{CC}			V
V _{O(SL)}	Low-level serial output voltage	I _O = 1 mA		0.1	0.4	V
I _{OZ(SD)}	3-state current serial-data output	V _{CC} = 0 V to 5.5 V	-10	1	10	μA
V _{O(CFLT)}	Fault-interrupt output voltage	I _O = 1 mA		0.1	0.5	V
V _{I(COMP)}	Fault-external reference voltage, (TPIC44L01/L02 only)	V _{COMPEN} = H	0.25		3	V
V _{I(COMP)}	Fault-external reference voltage, (TPIC44L03 only)	V _{COMPEN} = H	1		3	V
V _C	Output clamp voltage, (TPIC44L01/L02 only)	dc < 1%, t _w = 100 μs	47	55	63	V
V _C	Output clamp voltage, (TPIC44L03 only)	dc < 1%, t _w = 100 μs	47	53.5	60	V



TPIC44L01, TPIC44L02, TPIC44L03 4-CHANNEL SERIAL AND PARALLEL LOW-SIDE PRE-FET DRIVER

SLIS062B – NOVEMBER 1996 – REVISED AUGUST 2001

switching characteristics, $V_{CC} = 5\text{ V}$, $V_{bat} = 12\text{ V}$, $T_C = 25^\circ\text{C}$

PARAMETER		TEST CONDITIONS		MIN	TYP	MAX	UNIT
$t_{(STBFM)}$	Short-to-battery/shorted-load/open-load fault mask time	See Figures 14 and 15			60		μs
$t_{(STBDG)}$	Short-to-battery/shorted-load deglitch time	See Figure 14			8		μs
t_{PLH}	Propagation turnon delay time, \overline{CS} or IN0-IN3 to GATE0-GATE3	$C_{(gate)} = 400\text{ pF}$,	See Figure 1		4		μs
t_{PHL}	Propagation turnoff delay time, \overline{CS} or IN0-IN3 to GATE0-GATE3	$C_{(gate)} = 400\text{ pF}$,	See Figure 2		3.5		μs
$t_{r(1)}$	Rise time GATE0-GATE3	$C_{(gate)} = 400\text{ pF}$,	See Figure 3		3.5		μs
$t_{f(1)}$	Fall time, GATE0-GATE3	$C_{(gate)} = 400\text{ pF}$,	See Figure 4		3		μs
$f_{(SCLK)}$	Serial clock frequency					10	MHz
$t_{r(SB)}$	Refresh time, short-to-battery	TPIC46L01 only,	See Figure 14		10		ms
t_w	Refresh pulse width, short-to-battery	TPIC46L01 only,	See Figure 14		68		μs
$t_{su(1)}$	Setup time, $\overline{CS} \downarrow$ to $\uparrow\text{SCLK}$	See Figure 5			10		ns
$t_{pd(1)}$	Propagation delay time, $\overline{CS} \downarrow$ to SDO valid	$R_L = 10\text{ k}\Omega$, See Figure 6	$C_L = 200\text{ pF}$,		40		ns
$t_{pd(2)}$	Propagation delay time, $\text{SCLK} \downarrow$ to SDO valid	See Figure 6			20		ns
$t_{pd(3)}$	Propagation delay time, $\overline{CS} \uparrow$ to SDO 3-state	$R_L = 10\text{ k}\Omega$, See Figure 7	$C_L = 50\text{ pF}$,		2		μs
t_{r2}	Rise time, SDO 3-state to SDO valid	$R_L = 10\text{ k}\Omega$ to GND, $C_L = 200\text{ pF}$,	Over-battery fault, See Figure 8		30		ns
$t_{f(2)}$	Fall time, SDO 3-state to SDO valid	$R_L = 10\text{ k}\Omega$ to V_{CC} , $C_L = 200\text{ pF}$,	No faults, See Figure 9		20		ns
$t_{r(3)}$	Rise time, \overline{FLT}	$R_L = 10\text{ k}\Omega$, See Figure 10	$C_L = 50\text{ pF}$,		1.2		μs
$t_{f(3)}$	Fall time, \overline{FLT}	$R_L = 10\text{ k}\Omega$, See Figure 11	$C_L = 50\text{ pF}$,		15		ns

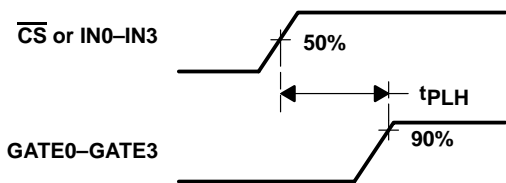

Figure 1

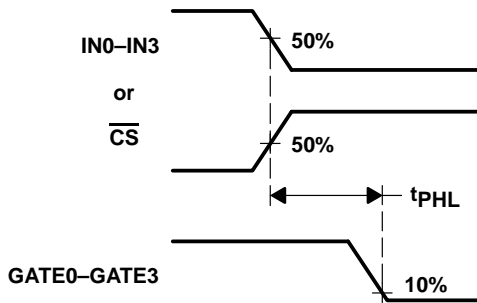

Figure 2

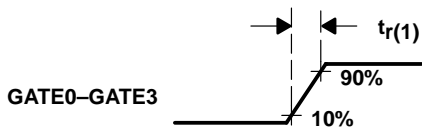

Figure 3

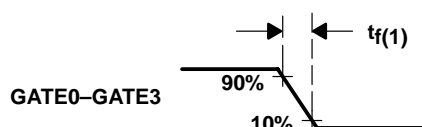

Figure 4

TPIC44L01, TPIC44L02, TPIC44L03 4-CHANNEL SERIAL AND PARALLEL LOW-SIDE PRE-FET DRIVER

SLIS062B – NOVEMBER 1996 – REVISED AUGUST 2001

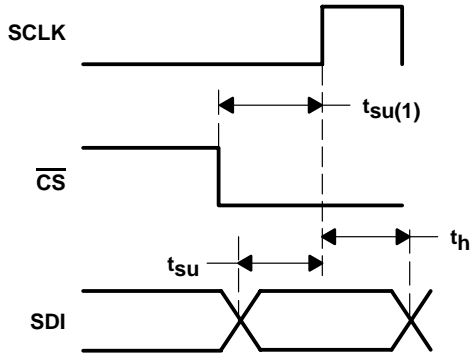

Figure 5

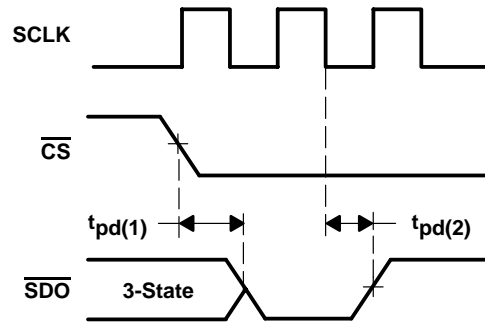

Figure 6

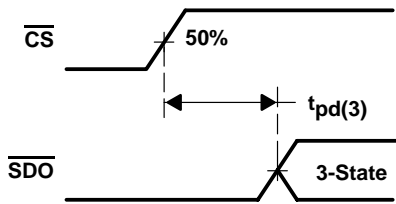

Figure 7

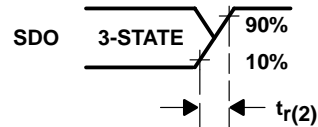

Figure 8

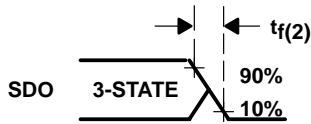

Figure 9

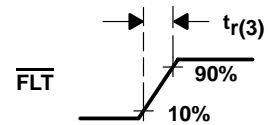

Figure 10

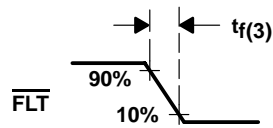

Figure 11

PRINCIPLES OF OPERATION

serial data operation

The TPIC44L01, TPIC44L02, and TPIC44L03 offer serial input interface to the microcontroller to transfer control data to the predriver and fault data back to the controller. The serial input interface consists of:

- SCLK – Serial clock
- \overline{CS} – Chip select
- SDI – Serial data input
- SDO – Serial data output

Serial data is shifted into the least significant bit (LSB) of the SDI shift register on the rising edge of the first SCLK after \overline{CS} has transitioned from 1 to 0. Four clock cycles are required to shift the first bit from the LSB to the most significant bit (MSB) of the shift register. Four clock cycles must occur before \overline{CS} transitions high for proper control of the outputs. Less than four clock cycles result in fault data being latched into the output control buffer. Eight bits of data can be shifted into the device, but the first 4 bits shifted out are always the fault data and the last 4 bits shifted in are always the output control data. A low-to-high transition on \overline{CS} latches the contents of the serial shift register into the output control register. A logic 0 input to SDI turns the corresponding parallel output off and a logic 1 input turns the output on (see Figure 12).

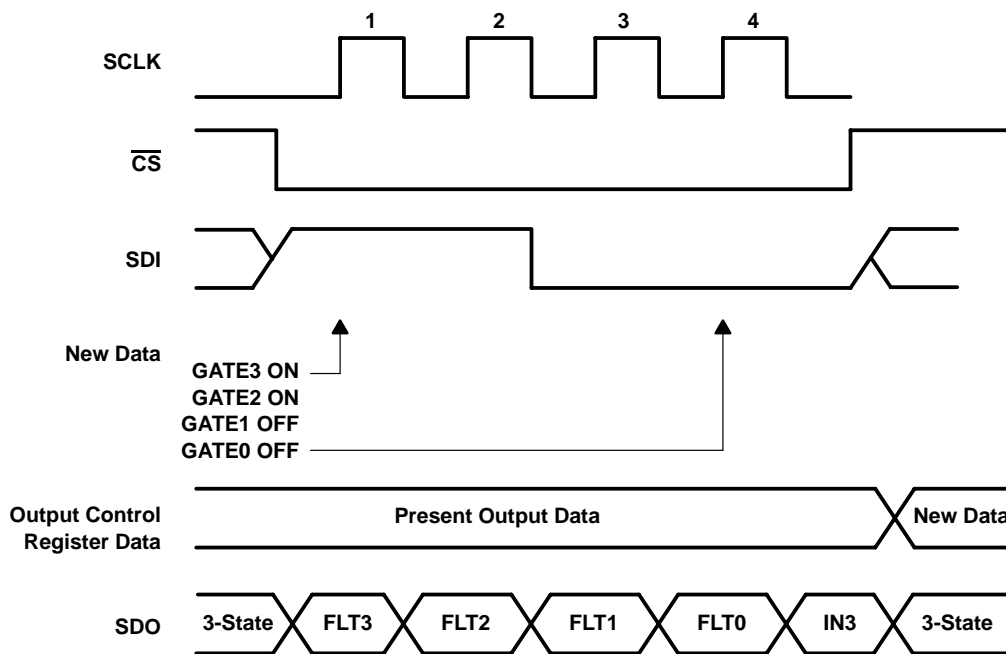

(a) 4-Bit Serial Word Example

Figure 12

TPIC44L01, TPIC44L02, TPIC44L03 4-CHANNEL SERIAL AND PARALLEL LOW-SIDE PRE-FET DRIVER

SLIS062B – NOVEMBER 1996 – REVISED AUGUST 2001

PRINCIPLES OF OPERATION

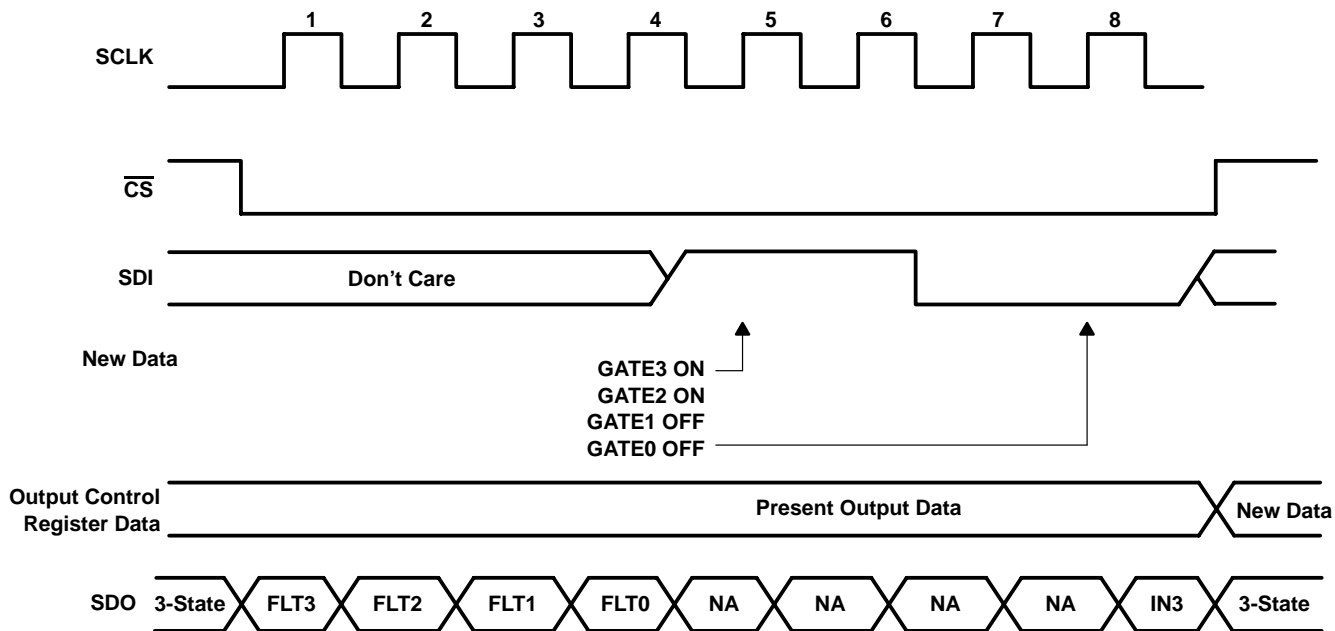

(b) 8-Bit Serial Word Example (Single Predriver)

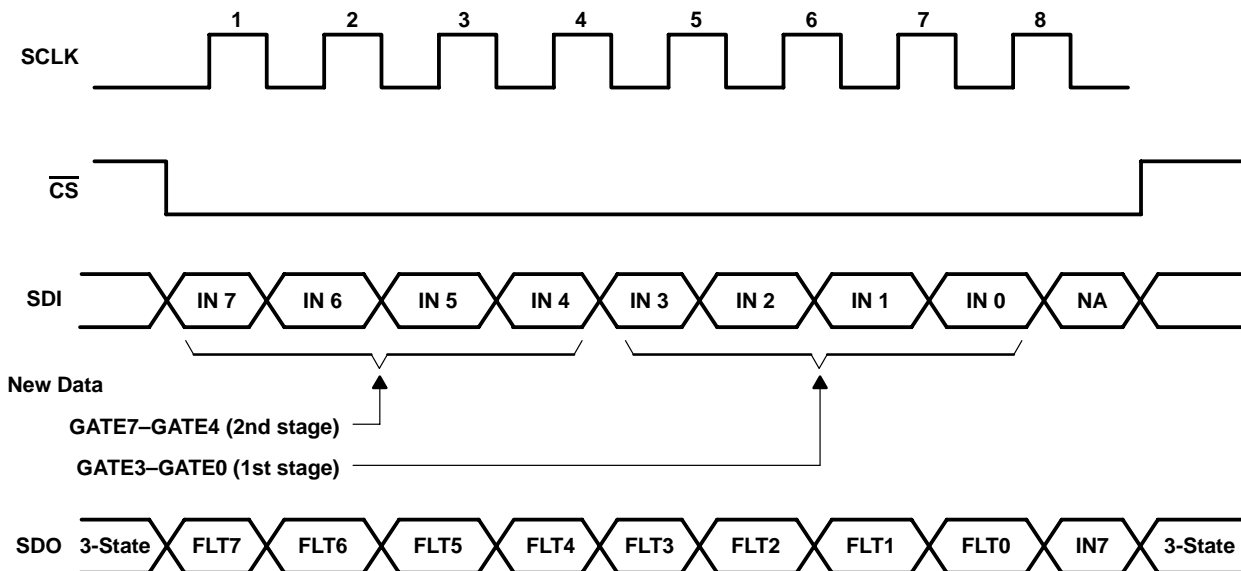

(c) 8-Bit Serial Word Example (Cascade: Two Predrivers)

Figure 12 (continued)



PRINCIPLES OF OPERATION

serial data operation (continued)

Data is shifted out of SDO on the falling edge of SCLK. The MSB of fault data is available after \overline{CS} is transitioned low. The remaining 3 bits of fault data are shifted out in the following three clock cycles. Fault data is latched into the serial register when \overline{CS} is transitioned low. A fault must be present on the high to low transition of \overline{CS} to be captured by the device. The \overline{CS} input must be transitioned to a high state after the last bit of serial data has been clocked into the device. The rising edge of \overline{CS} inhibits SDI, puts SDO into a high-impedance state, latches the 4 bits of serial data into the output control register, and clears and reenables the serial fault registers (see Figure 13). When a shorted-load condition occurs with the TPIC44L01 or TPIC44L03, then the controller must disable and reenables the channel to clear the fault register and \overline{FLT} . The TPIC44L02 automatically retries the output and the fault clears after the fault condition has been corrected.

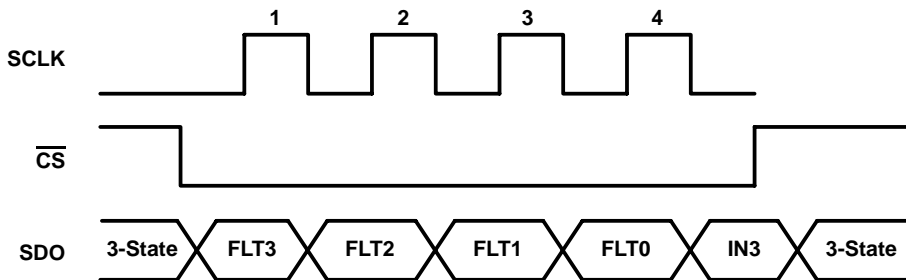

Figure 13

parallel input data operation

In addition to the serial interface, the TPIC44L01, TPIC44L02, and TPIC44L03 also provides a parallel interface to the microcontroller. The output turns on when either the parallel or the serial interface commands it to turn on. The parallel data terminals are real-time control inputs for the output drivers. SCLK and \overline{CS} are not required to transfer parallel input data to the output buffer. Fault data must be read over the serial data bus as described in the serial data operation section of this data sheet. The parallel input must be transitioned low and then high to clear and reenables a gate output after it has been disabled due to a shorted-load fault condition.

TPIC44L01, TPIC44L02, TPIC44L03 4-CHANNEL SERIAL AND PARALLEL LOW-SIDE PRE-FET DRIVER

SLIS062B – NOVEMBER 1996 – REVISED AUGUST 2001

PRINCIPLES OF OPERATION

chipset performance under fault conditions

The TPIC44L01, TPIC44L02, TPIC44L03, and power FET arrays are designed for normal operation over a battery-voltage range of 8 V to 24 V with load-fault detection from 4.8 V to 34 V. The TPIC44L01, TPIC44L02, and TPIC44L03 offer onboard fault detection to handle a variety of faults that may occur within a system. The circuit's primary function is to prevent damage to the load and the power FETs in the event that a fault occurs. Note that unused DRAIN0-DRAIN3 inputs must be connected to V_{BAT} through a pullup resistor to prevent false reporting of open-load fault conditions. The circuitry detects the fault, shuts off the output to the FET, and reports the fault to the microcontroller. The primary faults under consideration are:

1. Shorted load
2. Open load
3. Over-battery voltage shutdown
4. Under-battery voltage shutdown (TPIC44L01 and TPIC44L02 only)

NOTE:

An undervoltage fault may be detected when V_{CC} and V_{BAT} are applied to the device. The controller should initialize the fault register after power up to clear any false fault reports.

shorted-load fault condition

The TPIC44L01, TPIC44L02, and TPIC44L03 monitor the drain voltage of each channel to detect shorted-load conditions. The onboard deglitch timer starts running when the gate output to the power FET transitions from the off state to the on state. The timer provides a 60- μ s deglitch time, $t_{(STBFM)}$, to allow the drain voltage to stabilize after the power FET has been turned on. The deglitch time is only enabled for the first 60 μ s after the FET has been turned on. After the deglitch delay time, the drain voltage is checked to verify that it is less than the fault reference voltage. When it is greater than the reference voltage for at least the short-to-battery deglitch time, $t_{(STBDG)}$, \overline{FLT} flags the microcontroller that a fault condition exists and the gate output is automatically shut off (TPIC44L01 and TPIC44L03) until the error condition has been corrected.

An overheating condition on the FET occurs when the controller continually tries to reenable the output under shorted-load fault conditions. When a shorted-load fault is detected using the TPIC44L02, the gate output is transitioned into a low-duty cycle, PWM signal to protect the FET from overheating. The PWM rate is defined as $t_{(SB)}$ and the pulse width is defined as t_w . The gate output remains in this state until the fault has been corrected or until the controller disables the gate output.

The microcontroller can read the serial port on the predriver to isolate which channel reported the fault condition. Fault bits 0-3 distinguish faults for each of the output channels. When a shorted-load condition occurs with the TPIC44L01 or TPIC44L03, the controller must disable and reenable the channel to clear the fault register and \overline{FLT} . The TPIC44L02 automatically retries the output and the fault clears after the fault condition has been corrected. Figure 14 illustrates operation after a gate output has been turned on. The gate to the power FET is turned on and the deglitch timer starts running. Under normal operation T1 turns on and the drain operates below the reference point set at U1. The output of U1 is low and a fault condition is not flagged.



POST OFFICE BOX 655303 • DALLAS, TEXAS 75265

TPIC44L01, TPIC44L02, TPIC44L03 4-CHANNEL SERIAL AND PARALLEL LOW-SIDE PRE-FET DRIVER

SLIS062B – NOVEMBER 1996 – REVISED AUGUST 2001

PRINCIPLES OF OPERATION

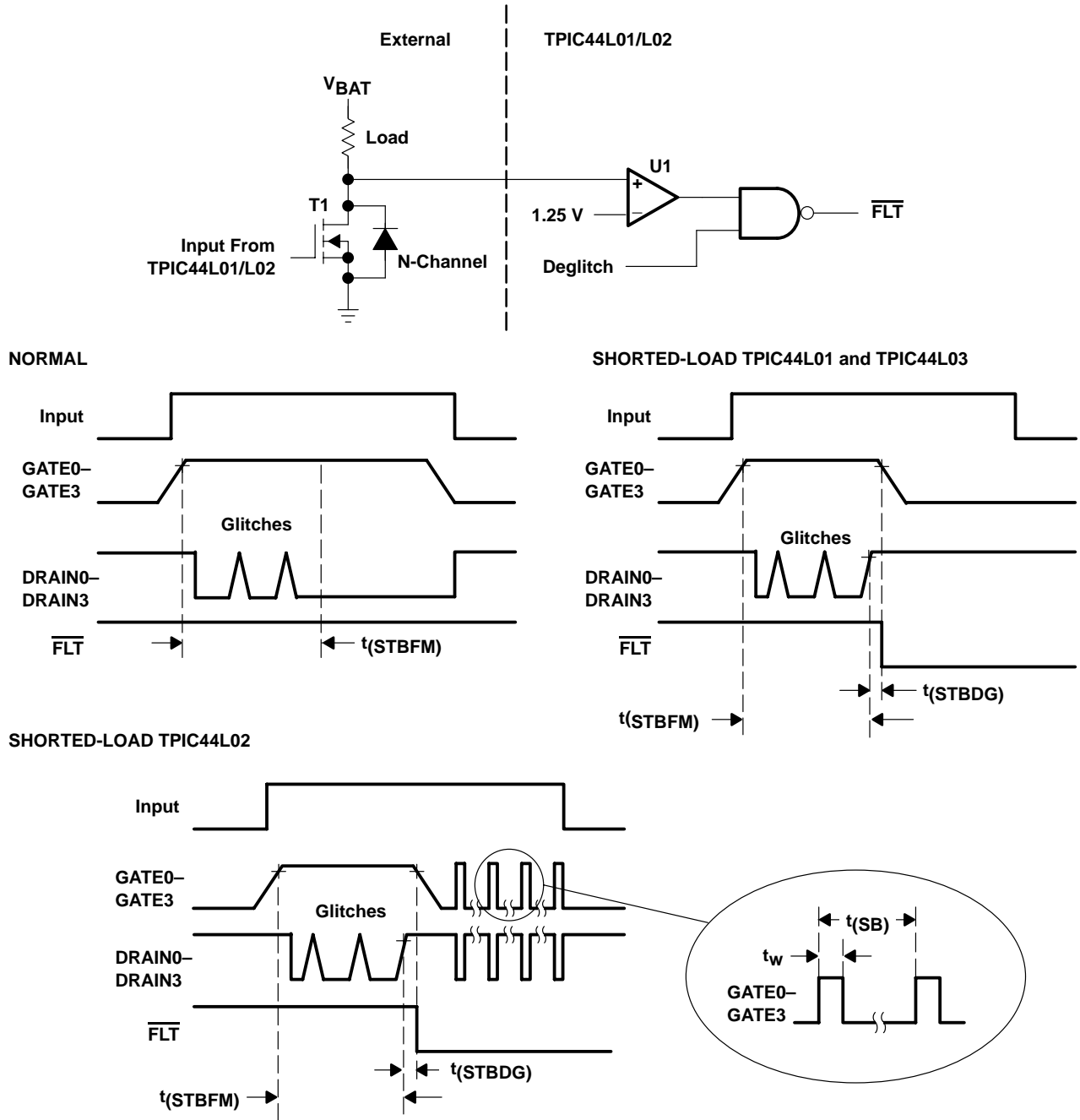

Figure 14

TPIC44L01, TPIC44L02, TPIC44L03

4-CHANNEL SERIAL AND PARALLEL LOW-SIDE PRE-FET DRIVER

SLIS062B – NOVEMBER 1996 – REVISED AUGUST 2001

PRINCIPLES OF OPERATION

open load

The TPIC44L01, TPIC44L02, and TPIC44L03 monitor the drain of each power FET for open circuit conditions that may exist. The 60- μ A current source is provided to monitor open load fault conditions. Open-load faults are only detected when the power FET is turned off. When load impedance is open or substantially high, the 60- μ A current source has adequate drive to pull the drain of T1 below the fault reference threshold on the detection circuit. Unused DRAIN0–DRAIN3 inputs must be connected to V_{BAT} through a pullup resistor to prevent false reporting of open-load fault conditions. The onboard deglitch timer starts running when the TPIC44L01, TPIC44L02, and TPIC44L03 gate output to the power FET transitions to the off state. The timer provides a 60- μ s deglitch time, $t_{(STBFM)}$ to allow the drain voltage to stabilize after the power FET has been turned off. The deglitch time is only enabled for the first 60 μ s after the FET has been turned off. After the deglitch delay time, the drain is checked to verify that it is greater than the fault reference voltage. When it is less than the reference voltage, a fault is flagged to the microcontroller through \overline{FLT} that an open-load fault condition exists. The microcontroller can then read the serial port on the TPIC44L01, TPIC44L02, and TPIC44L03 to isolate which channel reported the fault condition. Fault bits 0–3 distinguish faults for each of the output channels. Figure 15 illustrates the operation of the open-load detection circuit. This feature provides useful information to the microcontroller to isolate system failures and warn the operator that a problem exists. Examples of such applications would be a warning that a light bulb filament may be open, solenoid coils may be open, etc.

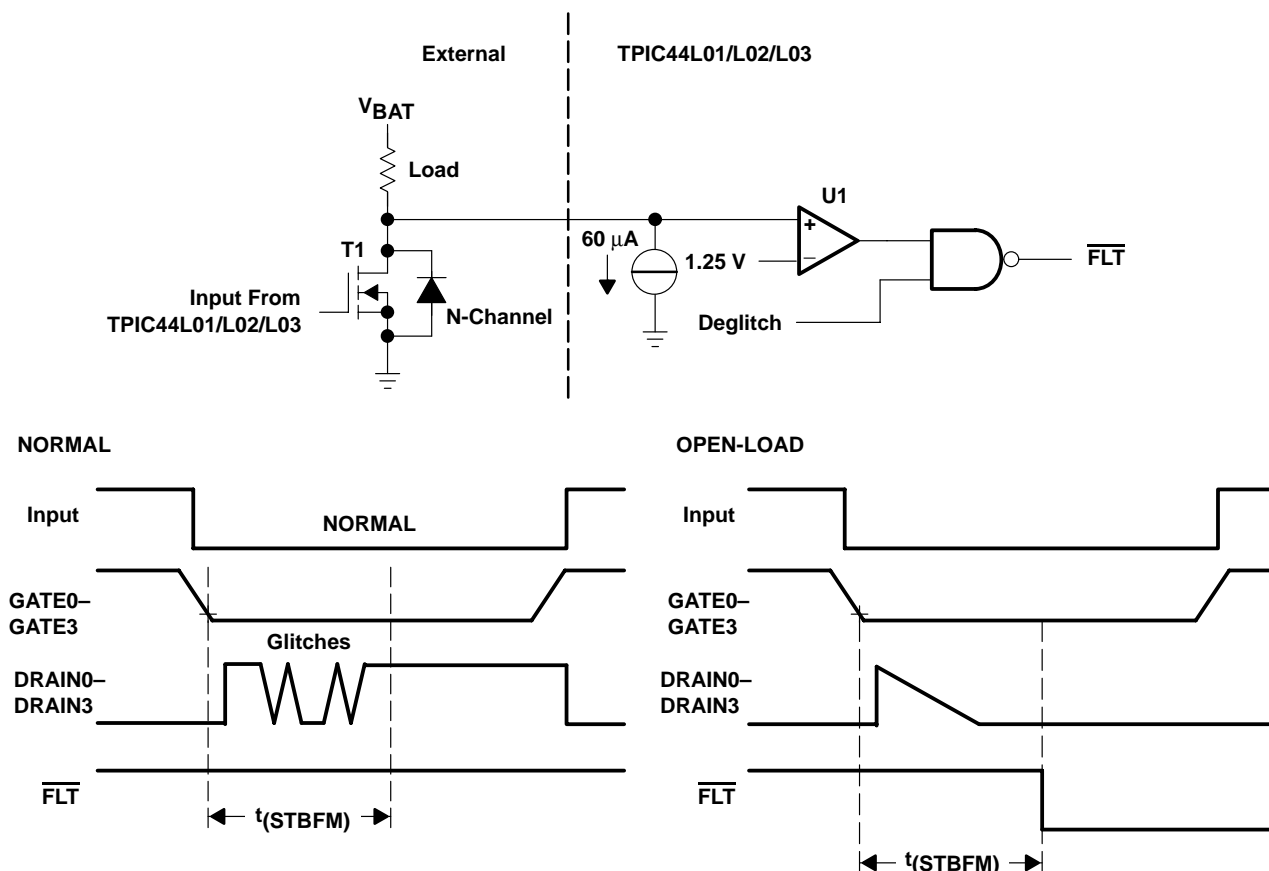

Figure 15

PRINCIPLES OF OPERATION

over-battery-voltage shutdown

The TPIC44L01, TPIC44L02, and TPIC44L03 monitor the battery voltage to prevent the power FETs turning on in the event that the battery voltage is too high. This condition may occur due to voltage transients resulting from a loose battery connection. The TPIC44L01, TPIC44L02, and TPIC44L03 turns the power FET off when the battery voltage is above 34 V to prevent possible damage to the load and the FET. GATE(0–3) output goes back to normal operation after the overvoltage condition has been corrected. An over-battery voltage fault is flagged to the controller through $\overline{\text{FLT}}$. The over-battery voltage fault is not reported in the serial fault word. When an overvoltage condition occurs, the device reports the battery fault, but disables fault reporting for open and shorted-load conditions. Fault reporting for open and shorted-load conditions are reenabled after the battery fault condition has been corrected. When the fault condition is removed before the $\overline{\text{CS}}$ signal transitions low, the fault condition is not captured in the serial fault register. The fault flag resets on a high-to-low transition of $\overline{\text{CS}}$ provided no other faults are present in the device. Figure 16 illustrates the operation of the over-battery voltage detection circuit.

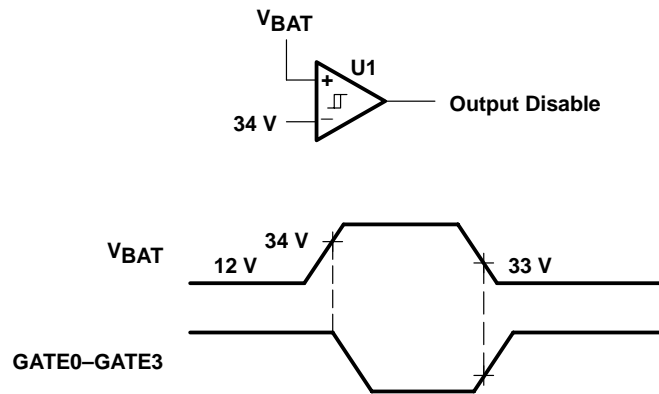

Figure 16

TPIC44L01, TPIC44L02, TPIC44L03 4-CHANNEL SERIAL AND PARALLEL LOW-SIDE PRE-FET DRIVER

SLIS062B – NOVEMBER 1996 – REVISED AUGUST 2001

PRINCIPLES OF OPERATION

under-battery-voltage shutdown (TPIC44L01 and TPIC44L02 only)

The TPIC44L01 and TPIC44L02 monitor the battery voltage to prevent the power FETs from being turned on in the event that the battery voltage is too low. When the battery voltage is below 4.8 V, then GATE0–GATE3 may not provide sufficient gate voltage to the power FETs to minimize the on-resistance that could result in a thermal stress on the FET. The output goes back to normal operation after the undervoltage condition has been corrected. An under-battery voltage fault is flagged to the controller through $\overline{\text{FLT}}$. The under-battery voltage fault is not reported in the serial fault word. When an under-battery voltage condition occurs, the device reports the battery fault but disables fault reporting for open- and shorted-load conditions. When the fault condition is removed before the $\overline{\text{CS}}$ signal transitions low, the fault condition is not captured in the serial fault register. The fault flag resets on a high-to-low transition of $\overline{\text{CS}}$ provided no other faults are present in the device. Figure 17 illustrates the operation of the under-battery voltage detection circuit.

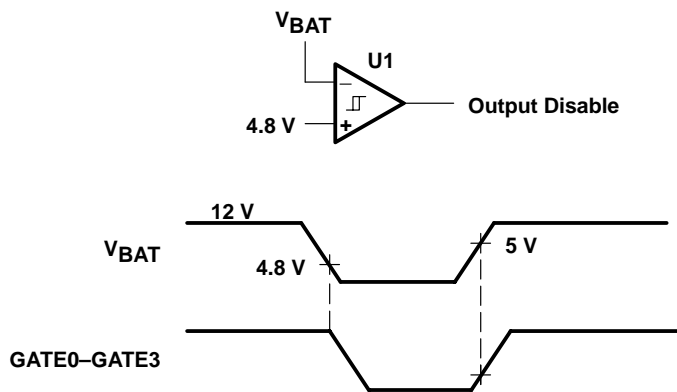

Figure 17

PRINCIPLES OF OPERATION

inductive voltage transients

A typical application for the predriver/power FET circuit is to switch inductive loads. When an inductive load is switched off, a large voltage spike can occur. These spikes can exceed the maximum V_{DS} rating for the external FET and damage the device when the proper protection is not in place. The FET can be protected from these transients through a variety of methods using external components. The TPIC44L01, TPIC44L02, and TPIC44L03 offer that protection in the form of a Zener diode stack connected between the DRAIN input and GATE output (see Figure 18). Zener diode Z1 turns the FET on to dissipate the transient energy. GATE diode Z2 is provided to prevent the gate voltage from exceeding 13 V during normal operation and transient protection.

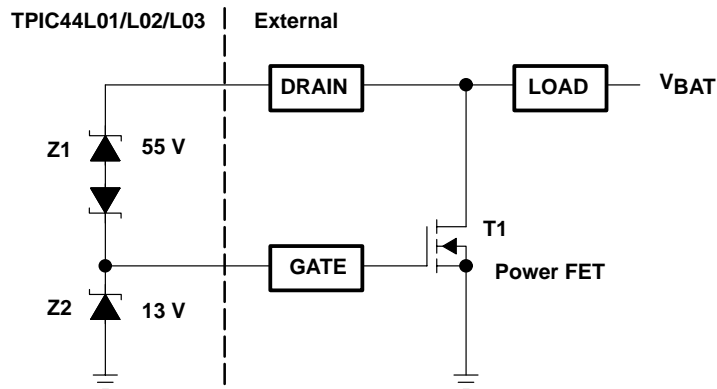

Figure 18

TPIC44L01, TPIC44L02, TPIC44L03 4-CHANNEL SERIAL AND PARALLEL LOW-SIDE PRE-FET DRIVER

SLIS062B – NOVEMBER 1996 – REVISED AUGUST 2001

PRINCIPLES OF OPERATION

external fault reference input

The TPIC44L01, TPIC44L02, and TPIC44L03 compare each channel drain voltage to a fault reference to detect shorted-load and open-load conditions. The user has the option of using the internally generated 1.25-V fault reference or providing an external reference voltage through VCOMP. The internal reference is selected by connecting VCOMPEN to GND and VCOMP is selected by connecting VCOMPEN to V_{CC} (see Figure 19). Proper layout techniques should be used in the grounding network for the VCOMP circuit on the TPIC44L01, TPIC44L02, and TPIC44L03. The ground for the predriver and VCOMP network should be connected to a Kelvin ground if available; otherwise, they should make single-point contact back to the power ground of the FET array. Improper grounding techniques can result in inaccuracies in detecting faults.

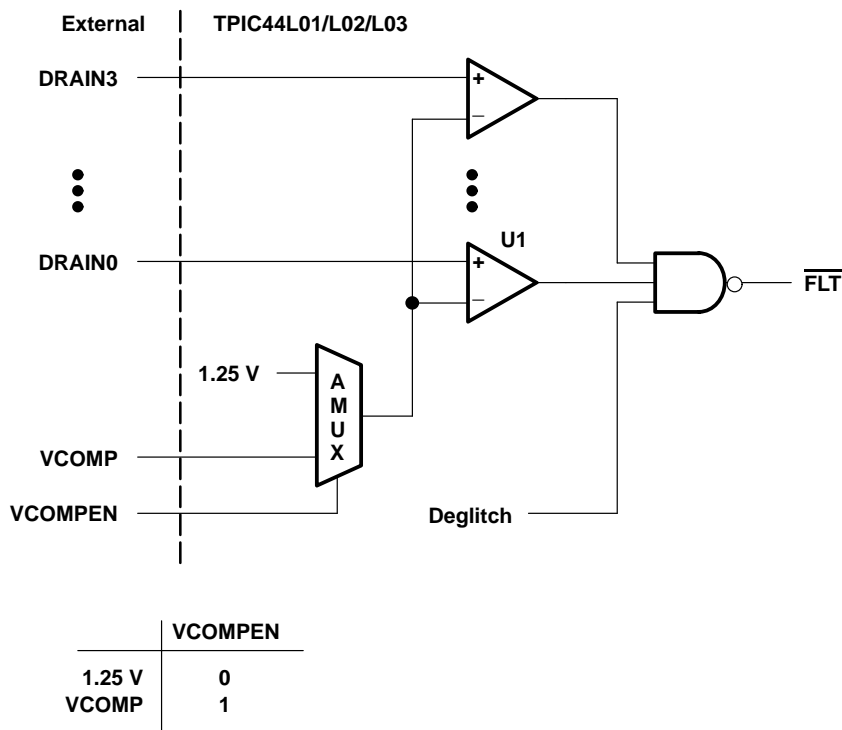

Figure 19

PACKAGING INFORMATION

Orderable Device	Status (1)	Package Type	Package Drawing	Pins	Package Qty	Eco Plan (2)	Lead/Ball Finish (6)	MSL Peak Temp (3)	Op Temp (°C)	Device Marking (4/5)	Samples
TPIC44L01DB	NRND	SSOP	DB	24	60	Green (RoHS & no Sb/Br)	CU NIPDAU	Level-1-260C-UNLIM	-40 to 125	TPIC44L01	
TPIC44L01DBG4	NRND	SSOP	DB	24	60	Green (RoHS & no Sb/Br)	CU NIPDAU	Level-1-260C-UNLIM		TPIC44L01	
TPIC44L01DBR	ACTIVE	SSOP	DB	24	2000	Green (RoHS & no Sb/Br)	CU NIPDAU	Level-1-260C-UNLIM		TPIC44L01	Samples
TPIC44L02DB	ACTIVE	SSOP	DB	24	60	Green (RoHS & no Sb/Br)	CU NIPDAU	Level-1-260C-UNLIM	-40 to 125	TPIC44L02	Samples
TPIC44L02DBG4	ACTIVE	SSOP	DB	24	60	Green (RoHS & no Sb/Br)	CU NIPDAU	Level-1-260C-UNLIM		TPIC44L02	Samples
TPIC44L02DBR	ACTIVE	SSOP	DB	24	2000	Green (RoHS & no Sb/Br)	CU NIPDAU	Level-1-260C-UNLIM		TPIC44L02	Samples
TPIC44L02DBRG4	ACTIVE	SSOP	DB	24		Green (RoHS & no Sb/Br)	CU NIPDAU	Level-1-260C-UNLIM		(IC44L02 ~ TPIC44L02)	Samples

(1) The marketing status values are defined as follows:

ACTIVE: Product device recommended for new designs.

LIFEBUY: TI has announced that the device will be discontinued, and a lifetime-buy period is in effect.

NRND: Not recommended for new designs. Device is in production to support existing customers, but TI does not recommend using this part in a new design.

PREVIEW: Device has been announced but is not in production. Samples may or may not be available.

OBSELETE: TI has discontinued the production of the device.

(2) Eco Plan - The planned eco-friendly classification: Pb-Free (RoHS), Pb-Free (RoHS Exempt), or Green (RoHS & no Sb/Br) - please check <http://www.ti.com/productcontent> for the latest availability information and additional product content details.

TBD: The Pb-Free/Green conversion plan has not been defined.

Pb-Free (RoHS): TI's terms "Lead-Free" or "Pb-Free" mean semiconductor products that are compatible with the current RoHS requirements for all 6 substances, including the requirement that lead not exceed 0.1% by weight in homogeneous materials. Where designed to be soldered at high temperatures, TI Pb-Free products are suitable for use in specified lead-free processes.

Pb-Free (RoHS Exempt): This component has a RoHS exemption for either 1) lead-based flip-chip solder bumps used between the die and package, or 2) lead-based die adhesive used between the die and leadframe. The component is otherwise considered Pb-Free (RoHS compatible) as defined above.

Green (RoHS & no Sb/Br): TI defines "Green" to mean Pb-Free (RoHS compatible), and free of Bromine (Br) and Antimony (Sb) based flame retardants (Br or Sb do not exceed 0.1% by weight in homogeneous material)

(3) MSL, Peak Temp. - The Moisture Sensitivity Level rating according to the JEDEC industry standard classifications, and peak solder temperature.

(4) There may be additional marking, which relates to the logo, the lot trace code information, or the environmental category on the device.

⁽⁵⁾ Multiple Device Markings will be inside parentheses. Only one Device Marking contained in parentheses and separated by a "-" will appear on a device. If a line is indented then it is a continuation of the previous line and the two combined represent the entire Device Marking for that device.

⁽⁶⁾ Lead/Ball Finish - Orderable Devices may have multiple material finish options. Finish options are separated by a vertical ruled line. Lead/Ball Finish values may wrap to two lines if the finish value exceeds the maximum column width.

Important Information and Disclaimer:The information provided on this page represents TI's knowledge and belief as of the date that it is provided. TI bases its knowledge and belief on information provided by third parties, and makes no representation or warranty as to the accuracy of such information. Efforts are underway to better integrate information from third parties. TI has taken and continues to take reasonable steps to provide representative and accurate information but may not have conducted destructive testing or chemical analysis on incoming materials and chemicals. TI and TI suppliers consider certain information to be proprietary, and thus CAS numbers and other limited information may not be available for release.

In no event shall TI's liability arising out of such information exceed the total purchase price of the TI part(s) at issue in this document sold by TI to Customer on an annual basis.

TAPE AND REEL INFORMATION



QUADRANT ASSIGNMENTS FOR PIN 1 ORIENTATION IN TAPE



*All dimensions are nominal

Device	Package Type	Package Drawing	Pins	SPQ	Reel Diameter (mm)	Reel Width W1 (mm)	A0 (mm)	B0 (mm)	K0 (mm)	P1 (mm)	W (mm)	Pin1 Quadrant
TPIC44L01DBR	SSOP	DB	24	2000	330.0	16.4	8.2	8.8	2.5	12.0	16.0	Q1
TPIC44L02DBR	SSOP	DB	24	2000	330.0	16.4	8.2	8.8	2.5	12.0	16.0	Q1
TPIC44L02DBRG4	SSOP	DB	24	0	330.0	16.4	8.2	8.8	2.5	12.0	16.0	Q1

TAPE AND REEL BOX DIMENSIONS

*All dimensions are nominal

Device	Package Type	Package Drawing	Pins	SPQ	Length (mm)	Width (mm)	Height (mm)
TPIC44L01DBR	SSOP	DB	24	2000	367.0	367.0	38.0
TPIC44L02DBR	SSOP	DB	24	2000	367.0	367.0	38.0
TPIC44L02DBRG4	SSOP	DB	24	0	367.0	367.0	38.0

IMPORTANT NOTICE

Texas Instruments Incorporated (TI) reserves the right to make corrections, enhancements, improvements and other changes to its semiconductor products and services per JESD46, latest issue, and to discontinue any product or service per JESD48, latest issue. Buyers should obtain the latest relevant information before placing orders and should verify that such information is current and complete.

TI's published terms of sale for semiconductor products (<http://www.ti.com/sc/docs/stdterms.htm>) apply to the sale of packaged integrated circuit products that TI has qualified and released to market. Additional terms may apply to the use or sale of other types of TI products and services.

Reproduction of significant portions of TI information in TI data sheets is permissible only if reproduction is without alteration and is accompanied by all associated warranties, conditions, limitations, and notices. TI is not responsible or liable for such reproduced documentation. Information of third parties may be subject to additional restrictions. Resale of TI products or services with statements different from or beyond the parameters stated by TI for that product or service voids all express and any implied warranties for the associated TI product or service and is an unfair and deceptive business practice. TI is not responsible or liable for any such statements.

Buyers and others who are developing systems that incorporate TI products (collectively, "Designers") understand and agree that Designers remain responsible for using their independent analysis, evaluation and judgment in designing their applications and that Designers have full and exclusive responsibility to assure the safety of Designers' applications and compliance of their applications (and of all TI products used in or for Designers' applications) with all applicable regulations, laws and other applicable requirements. Designer represents that, with respect to their applications, Designer has all the necessary expertise to create and implement safeguards that (1) anticipate dangerous consequences of failures, (2) monitor failures and their consequences, and (3) lessen the likelihood of failures that might cause harm and take appropriate actions. Designer agrees that prior to using or distributing any applications that include TI products, Designer will thoroughly test such applications and the functionality of such TI products as used in such applications.

TI's provision of technical, application or other design advice, quality characterization, reliability data or other services or information, including, but not limited to, reference designs and materials relating to evaluation modules, (collectively, "TI Resources") are intended to assist designers who are developing applications that incorporate TI products; by downloading, accessing or using TI Resources in any way, Designer (individually or, if Designer is acting on behalf of a company, Designer's company) agrees to use any particular TI Resource solely for this purpose and subject to the terms of this Notice.

TI's provision of TI Resources does not expand or otherwise alter TI's applicable published warranties or warranty disclaimers for TI products, and no additional obligations or liabilities arise from TI providing such TI Resources. TI reserves the right to make corrections, enhancements, improvements and other changes to its TI Resources. TI has not conducted any testing other than that specifically described in the published documentation for a particular TI Resource.

Designer is authorized to use, copy and modify any individual TI Resource only in connection with the development of applications that include the TI product(s) identified in such TI Resource. NO OTHER LICENSE, EXPRESS OR IMPLIED, BY ESTOPPEL OR OTHERWISE TO ANY OTHER TI INTELLECTUAL PROPERTY RIGHT, AND NO LICENSE TO ANY TECHNOLOGY OR INTELLECTUAL PROPERTY RIGHT OF TI OR ANY THIRD PARTY IS GRANTED HEREIN, including but not limited to any patent right, copyright, mask work right, or other intellectual property right relating to any combination, machine, or process in which TI products or services are used. Information regarding or referencing third-party products or services does not constitute a license to use such products or services, or a warranty or endorsement thereof. Use of TI Resources may require a license from a third party under the patents or other intellectual property of the third party, or a license from TI under the patents or other intellectual property of TI.

TI RESOURCES ARE PROVIDED "AS IS" AND WITH ALL FAULTS. TI DISCLAIMS ALL OTHER WARRANTIES OR REPRESENTATIONS, EXPRESS OR IMPLIED, REGARDING RESOURCES OR USE THEREOF, INCLUDING BUT NOT LIMITED TO ACCURACY OR COMPLETENESS, TITLE, ANY EPIDEMIC FAILURE WARRANTY AND ANY IMPLIED WARRANTIES OF MERCHANTABILITY, FITNESS FOR A PARTICULAR PURPOSE, AND NON-INFRINGEMENT OF ANY THIRD PARTY INTELLECTUAL PROPERTY RIGHTS. TI SHALL NOT BE LIABLE FOR AND SHALL NOT DEFEND OR INDEMNIFY DESIGNER AGAINST ANY CLAIM, INCLUDING BUT NOT LIMITED TO ANY INFRINGEMENT CLAIM THAT RELATES TO OR IS BASED ON ANY COMBINATION OF PRODUCTS EVEN IF DESCRIBED IN TI RESOURCES OR OTHERWISE. IN NO EVENT SHALL TI BE LIABLE FOR ANY ACTUAL, DIRECT, SPECIAL, COLLATERAL, INDIRECT, PUNITIVE, INCIDENTAL, CONSEQUENTIAL OR EXEMPLARY DAMAGES IN CONNECTION WITH OR ARISING OUT OF TI RESOURCES OR USE THEREOF, AND REGARDLESS OF WHETHER TI HAS BEEN ADVISED OF THE POSSIBILITY OF SUCH DAMAGES.

Unless TI has explicitly designated an individual product as meeting the requirements of a particular industry standard (e.g., ISO/TS 16949 and ISO 26262), TI is not responsible for any failure to meet such industry standard requirements.

Where TI specifically promotes products as facilitating functional safety or as compliant with industry functional safety standards, such products are intended to help enable customers to design and create their own applications that meet applicable functional safety standards and requirements. Using products in an application does not by itself establish any safety features in the application. Designers must ensure compliance with safety-related requirements and standards applicable to their applications. Designer may not use any TI products in life-critical medical equipment unless authorized officers of the parties have executed a special contract specifically governing such use. Life-critical medical equipment is medical equipment where failure of such equipment would cause serious bodily injury or death (e.g., life support, pacemakers, defibrillators, heart pumps, neurostimulators, and implantables). Such equipment includes, without limitation, all medical devices identified by the U.S. Food and Drug Administration as Class III devices and equivalent classifications outside the U.S.

TI may expressly designate certain products as completing a particular qualification (e.g., Q100, Military Grade, or Enhanced Product). Designers agree that it has the necessary expertise to select the product with the appropriate qualification designation for their applications and that proper product selection is at Designers' own risk. Designers are solely responsible for compliance with all legal and regulatory requirements in connection with such selection.

Designer will fully indemnify TI and its representatives against any damages, costs, losses, and/or liabilities arising out of Designer's non-compliance with the terms and provisions of this Notice.